

HR1221W(12V4.5Ah)

Ventura

● Outer dimensions (mm)

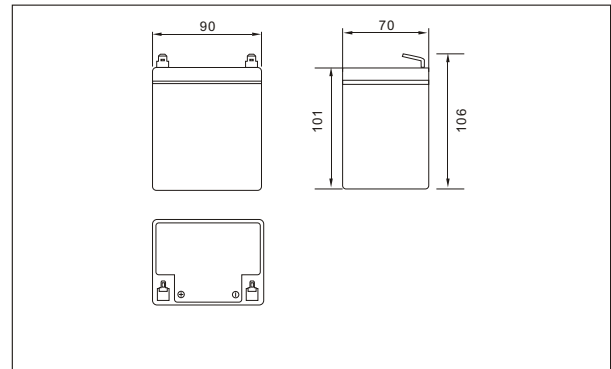

● Specifications

Nominal Voltage		12V
CAPACITY(15 minutes rate to 1.67V/cell)		21W
Rated capacity (20 hour rate)		4.5Ah
Dimensions	Total Height	106mm (4.17 inches)
	Height	100mm (3.95 inches)
	Length	90mm (3.54 inches)
	Width	70mm (2.76 inches)
Weight Approx		1.88Kg (4.14lbs)

● Terminal Type (mm)

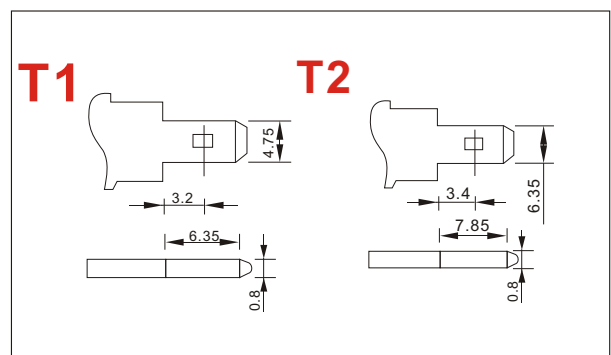

● Characteristics

Capacity 25°C(77°F)	30min rate 15min rate 6min rate	71W 126W 242W
Internal Resistance	Full charged Battery at 25°C(77°F)	24 mΩ
Capacity affected by Temperature (20hour rate)	40°C(104°F) 25°C(77°F) 0°C(32°F) -15°C(5°F)	102% 100% 85% 65%
Self-Discharge at 25°C(77°F)	Capacity after 3 month storage Capacity after 6 month storage Capacity after 12 month storage	91% 82% 64%
Terminal	T1, T2	
Charge (constant Voltage)	Cycle	Initial Charging Current less than 1.1A Voltage 14.10-14.40V
	Float	Voltage 13.50-13.80V

● Discharge Curves 25°C(77°F)

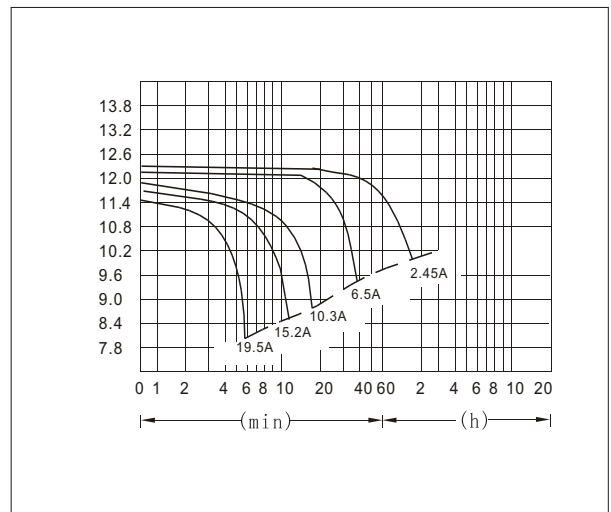

● Constant power discharge unit:watts(25°C, 77 °F)

	2MIN	4MIN	6MIN	8MIN	10MIN	15MIN	30MIN	60MIN
9.60V	416.9	311.2	242.5	207.3	178.4	131.6	75.1	40.4
10.02V	388.5	291.0	226.4	196.3	168.7	126.0	71.5	38.9
10.20V	376.5	282.4	219.5	191.7	164.5	123.6	71.0	38.2
10.50V	356.8	267.4	212.2	184.5	156.5	119.2	69.9	38.0
10.80V	337.2	252.9	205.0	177.3	148.4	114.9	68.7	37.9
11.10V	317.5	238.1	197.7	170.0	140.3	110.3	67.6	37.7

● Constant current discharge unit:A(25°C, 77 °F)

	5MIN	10MIN	15MIN	30MIN	60MIN	5h	10h	20h
9.60V	19.17	15.20	10.86	6.06	3.30	0.88	0.43	0.24
10.02V	18.25	14.22	10.76	5.80	3.15	0.86	0.42	0.24
10.20V	17.37	13.92	10.11	5.69	3.10	0.86	0.42	0.23
10.50V	16.51	13.17	9.72	5.58	3.09	0.82	0.41	0.23
10.80V	15.41	12.42	9.31	5.48	3.07	0.80	0.41	0.22
11.10V	14.77	12.11	8.91	5.36	3.05	0.77	0.40	0.22