

HR 12150W (40Ah)

Ventura

● Specifications

Nominal Voltage		12V
CAPACITY(15 minutes rate to 1.67V/cell)		150W
Rated capacity (10 hour rate)		40Ah
Dimensions	Total Height	171 mm (6.73 inches)
	Height	171 mm (6.73 inches)
	Length	196 mm (7.70 inches)
	Width	166mm (6.54 inches)
Weight Approx		14.8 Kg (32.6 lbs)

● Characteristics

Capacity 25°C(77°F)	30min rate	543W
	15min rate	900W
	5min rate	1588W
Internal Resistance	Full charged Battery at 25°C(77°F)	6 m Ω
Capacity affected by Temperature (20hour rate)	40°C(104°F)	102%
	25°C(77°F)	100%
	0°C(32°F)	85%
	-15°C(5°F)	65%
Self-Discharge at 25°C(77°F)	Capacity after 3 month storage	91%
	Capacity after 6 month storage	82%
	Capacity after 12 month storage	64%
Terminal	T9、T16	
Charge (constant Voltage)	Cycle	Initial Charging Current less than 10A Voltage 14.10-14.40V
	Float	Voltage 13.50-13.80V

● Constant power discharge :watts(25°C , 77 °F)

	5min	10min	15min	20min	30min	45min	60min	90min
9.60V	1588	1188	921	759	566	417	327	243
10.02V	1520	1149	900	746	553	401	319	235
10.2V	1452	1106	879	728	543	396	311	227
10.5V	1386	1080	856	715	532	383	298	216
10.8V	1318	967	759	663	473	342	270	207
11.1V	1174	864	689	612	440	321	254	197

● Outer dimensions (mm)

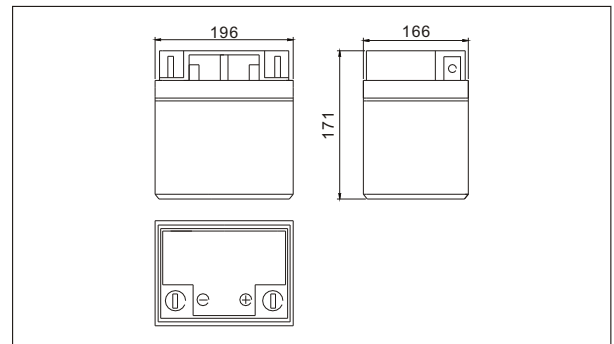

● Terminal Type (mm)

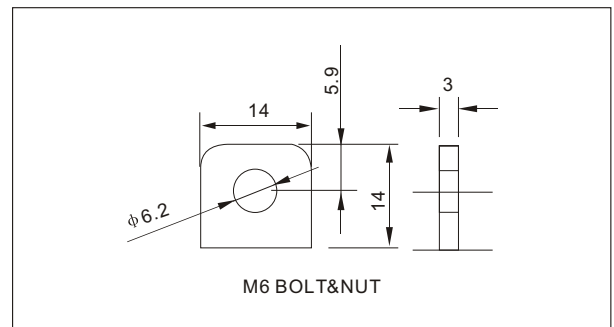

● Discharge Curves 25°C(77°F)

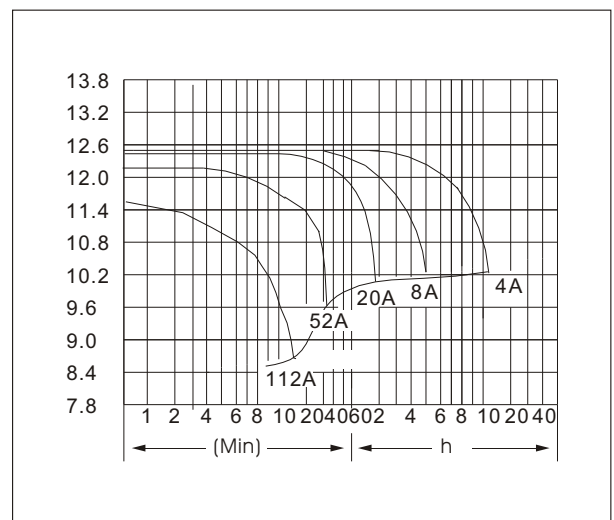

● Constant current discharge unit:A(25°C , 77 °F)

	5min	15min	30min	45min	60min	90min	5h	10h
9.60V	149.3	86.1	52.7	38.5	30.1	22.3	6.6	4.3
10.02V	141.4	82.7	50.6	36.6	28.8	21.2	6.6	4.2
10.2V	131.5	79.7	48.9	35.7	27.8	20.3	6.5	4.1
10.5V	121.6	74.6	45.4	32.8	25.4	19.0	6.4	4.0
10.8V	116.0	66.0	41.1	29.7	23.4	17.8	6.4	3.9
11.1V	101.8	60.4	38.3	27.8	21.9	16.9	6.2	3.8