

GP 12-4 12V4.0Ah

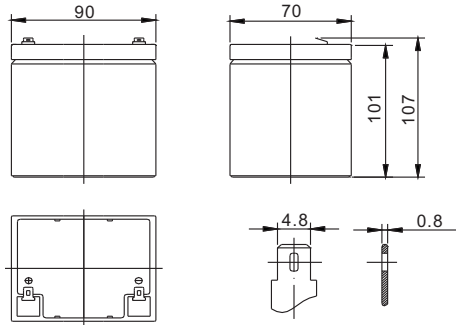

Dimension



T1
Terminal

Specification

Nominal Voltage		12 V
Capacity(20HR, 25°C)		4 Ah
Dimension	Length	90mm (3.54inch)
	Width	70mm (2.76inch)
	Height	101mm (3.98inch)
	Total Height	107mm (4.21inch)
Approx. Weight		1.40kg (3.07lbs)

Characteristics

Capacity 20°C (68°F) To 1.70V/Cell	20 hour rate	4.0Ah
	10 hour rate	3.8Ah
	5 hour rate	3.4Ah
	1 hour rate	2.53Ah
	15 min rate	1.87Ah
Internal resistance(Fully charged, 25°C)		Approx. 45m Ω
Capacity affected by temperature (20HR)	40°C	102%
	25°C	100%
	0°C	85%
	-15°C	65%
Self-discharge (25°C)	3 month	Remaining Capacity: 91%
	6 month	Remaining Capacity: 82%
	12 month	Remaining Capacity: 65%
Nominal operating temperature		25°C ±3°C(77°F ±5°F)
Operating temperature range		-15°C~50°C(5°F~122°F)
Float charging voltage(25°C)		13.60 to 13.80V
Cyclic charging voltage(25°C)		14.50 to 14.90V
Maximum charging current		1.2A
Terminal material		Copper
Maximum discharge current		60A(5 Sec.)

The Relationship for Open Circuit Voltage and Residual Capacity (25°C)

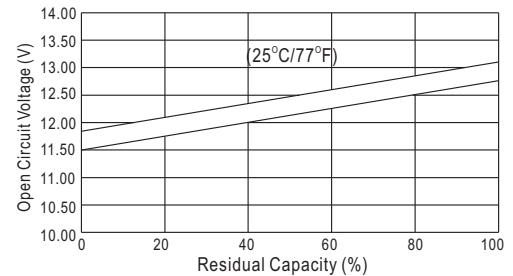

Charging Characteristics(25°C)

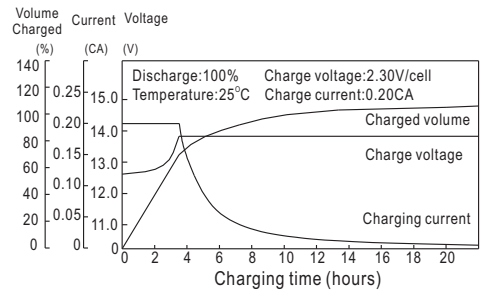

Cycle Life(25°C)

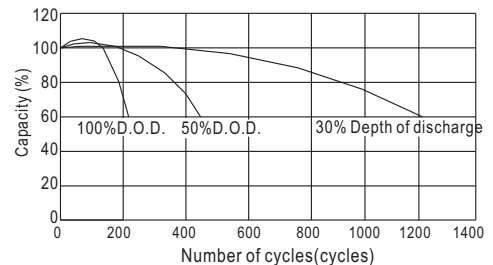

Constant Current Discharge Characteristics (A, 25°C)

F.V/TIME	5min	10min	15min	30min	60min	3h	5h	10h	20h
9.60V	14.4	9.20	7.82	4.30	2.64	0.97	0.69	0.38	0.20
10.2V	13.7	8.74	7.51	4.13	2.53	0.96	0.68	0.38	0.20
10.8V	12.9	8.22	7.13	3.92	2.40	0.94	0.67	0.37	0.20

Constant Power Discharge Characteristics (Watt, 25°C)

5min	10min	15min	30min	60min	3h	5h	10h	20h
161	104	89.1	49.3	30.6	11.5	8.24	4.51	2.40
153	98.6	85.6	47.3	29.3	11.4	8.12	4.47	2.40
144	92.7	81.3	44.9	27.8	11.2	8.00	4.47	2.40